

## High Energy Radial Lead Metal Oxide Varistors

October 1997

### Features

- High Peak Surge Current Rating ( $I_{TM}$ ) Up to 10kA, Single 8 x 20 Pulse, 20mm
- High Energy Ratings ( $W_{TM}$ )
- UL Recognized Component Listing to Safety Standard UL1449, Rev 2 (Pending)
- CSA Certification to Standard C22.2, NO.1 (Pending)
- VDE Listing (Pending)
- CECC Certified (42201- 006) (Pending)
- Standard Operating Voltage Range Compatible with Common AC Line Voltages (130VAC to 625VAC)
- Characterized for Maximum Standby Current (Leakage)
- Custom Voltage Types Available
- Standard Lead Form and Lead Space Options

### Description

The UltraMOV Series of Metal Oxide Varistors is designed for applications requiring high peak surge current ratings and high energy absorption capability. UltraMOVs are primarily intended for use in AC Line Voltage applications such as Transient Voltage Surge Suppressors (TVSS), Uninterruptible Power Supplies (UPS), AC Power Taps, AC Power Meters, or other products that require voltage clamping of high transient surge currents from sources such as lightning, inductive load switching, or capacitor bank switching.

These devices are produced in radial lead package sizes of 7, 10, 14, and 20mm and offered in a variety of lead forms. UltraMOVs are manufactured with recognized epoxy encapsulation and are rated for ambient temperatures up to 85°C with no derating. This Series is LASER-branded and is supplied in bulk, ammo pack (fan-fold), or tape and reel packaging. UltraMOVs also follow a different part number nomenclature than other Harris radial lead MOV Series.

### Packaging

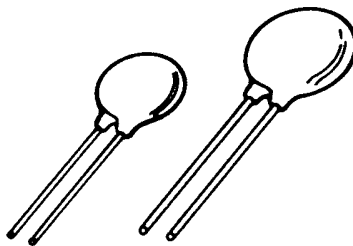

14mm, 20mm

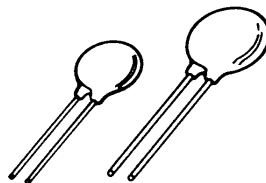

7mm, 10mm

## UltraMOV Series

**Absolute Maximum Ratings** For ratings of individual members of a series, see Device Ratings and Specifications chart

	ULTRAMOV SERIES	UNITS
Continuous:		
Steady State AC Voltage Range ( $V_{M(AC)}$ RMS) .....	130 to 625	V
Transient:		
Single-Pulse Peak Current ( $I_{TM}$ ) 8x20 $\mu$ s Wave (See Figure 2) .....	1,750 to 10,000	A
Single-Pulse Energy Range ( $W_{TM}$ ) 2ms Square Wave .....	12.5 to 720	J
Maximum Temporary Overvoltage of $V_{M(AC)}$		
5 Minutes at 25 $^{\circ}$ C .....	130	%
5 Minutes at 125 $^{\circ}$ C .....	125	%
Operating Ambient Temperature Range ( $T_A$ ) .....	-55 to 85	$^{\circ}$ C
Storage Temperature Range ( $T_{STG}$ ) .....	-55 to 125	$^{\circ}$ C
Temperature Coefficient ( $\alpha_V$ ) of Clamping Voltage ( $V_C$ ) at Specified Test Current. ....	<0.01	%/ $^{\circ}$ C
Hi-Pot Encapsulation Isolation Voltage Capability, Per MIL-STD-202, Method 301 .....	2500	V

*CAUTION: Stresses above those listed in "Absolute Maximum Ratings" may cause permanent damage to the device. This is a stress only rating and operation of the device at these or any other conditions above those indicated in the operational sections of this specification is not implied.*

### Device Ratings and Specifications

MODEL NUMBER	DEVICE MODEL NUMBER BRANDING	MAXIMUM RATING (85 $^{\circ}$ C)					CHARACTERISTICS (25 $^{\circ}$ C)				
		CONTINUOUS		TRANSIENT			VARISTOR VOLTAGE AT 1mA DC TEST CURRENT		MAXIMUM CLAMPING VOLTAGE 8 x 20 $\mu$ s		TYPICAL CAPACITANCE
		RMS VOLTS	DC VOLTS	ENERGY 2ms	PEAK CURRENT 8 x 20 $\mu$ s						
		$V_{M(AC)}$	$V_{M(DC)}$	$W_{TM}$	$I_{TM}$ 2 x PULSE	$I_{TM}$ 1 x PULSE	$V_{NOM}$ MIN	$V_{NOM}$ MAX	$V_C$	$I_{PK}$	f = 1MHz
(V)	(V)	(J)	(A)	(A)	(V)		(V)	(A)	(pF)		
V07E130	7V130	130	170	12.5	1200	1750	184	226	340	10	180
V10E130	10V130	130	170	25	2500	3500	184	226	340	25	450
V14E130	14V130	130	170	50	4500	6000	184	226	340	50	1000
V20E130	20V130	130	170	100	6500	10000	184	226	340	100	1900
V07E140	7V140	140	180	13.5	1200	1750	200	240	360	10	160
V10E140	10V140	140	180	27.5	2500	3500	200	240	360	25	400
V14E140	14V140	140	180	55	4500	6000	200	240	360	50	900
V20E140	20V140	140	180	110	6500	10000	200	240	360	100	1750
V07E150	7V150	150	200	15	1200	1750	216	264	395	10	150
V10E150	10V150	150	200	30	2500	3500	216	264	395	25	360
V14E150	14V150	150	200	60	4500	6000	216	264	395	50	800
V20E150	20V150	150	200	120	6500	10000	216	264	395	100	1600
V07E175	7V175	175	225	17	1200	1750	243	297	455	10	130
V10E175	10V175	175	225	35	2500	3500	243	297	455	25	350
V14E175	14V175	175	225	70	4500	6000	243	297	455	50	700
V20E175	20V175	175	225	135	6500	10000	243	297	455	100	1400
V07E230	7V230	230	300	20	1200	1750	324	396	595	10	100
V10E230	10V230	230	300	42	2500	3500	324	396	595	25	250
V14E230	14V230	230	300	80	4500	6000	324	396	595	50	550
V20E230	20V230	230	300	160	6500	10000	324	396	595	100	1100

## UltraMOV Series

### Device Ratings and Specifications (Continued)

MODEL NUMBER	DEVICE MODEL NUMBER BRANDING	MAXIMUM RATING (85°C)					CHARACTERISTICS (25°C)				
		CONTINUOUS		TRANSIENT			VARISTOR VOLTAGE AT 1mA DC TEST CURRENT		MAXIMUM CLAMPING VOLTAGE 8 x 20μs		TYPICAL CAPACITANCE
		RMS VOLTS	DC VOLTS	ENERGY 2ms	PEAK CURRENT 8 x 20μs		V <sub>NOM</sub> MIN	V <sub>NOM</sub> MAX	V <sub>C</sub>	I <sub>PK</sub>	f = 1MHz
		V <sub>M(AC)</sub>	V <sub>M(DC)</sub>	W <sub>TM</sub>	I <sub>TM</sub> 2 x PULSE	I <sub>TM</sub> 1 x PULSE					
		(V)	(V)	(J)	(A)	(A)	(V)		(V)	(A)	(pF)
V07E250	7V250	250	320	25	1200	1750	351	429	650	10	90
V10E250	10V250	250	320	50	2500	3500	351	429	650	25	220
V14E250	14V250	250	320	100	4500	6000	351	429	650	50	500
V20E250	20V250	250	320	170	6500	10000	351	429	650	100	1000
V07E275	7V275	275	350	28	1200	1750	387	473	710	10	80
V10E275	10V275	275	350	55	2500	3500	387	473	710	25	200
V14E275	14V275	275	350	110	4500	6000	387	473	710	50	450
V20E275	20V275	275	350	190	6500	10000	387	473	710	100	900
V07E300	7V300	300	385	30	1200	1750	423	517	775	10	70
V10E300	10V300	300	385	60	2500	3500	423	517	775	25	180
V14E300	14V300	300	385	125	4500	6000	423	517	775	50	400
V20E300	20V300	300	385	250	6500	10000	423	517	775	100	800
V07E320	7V320	320	420	32	1200	1750	459	561	840	10	65
V10E320	10V320	320	420	67	2500	3500	459	561	840	25	170
V14E320	14V320	320	420	136	4500	6000	459	561	840	50	380
V20E320	20V320	320	420	273	6500	10000	459	561	840	100	750
V07E385	7V385	385	505	36	1200	1750	558	682	1025	10	60
V10E385	10V385	385	505	75	2500	3500	558	682	1025	25	160
V14E385	14V385	385	505	150	4500	6000	558	682	1025	50	360
V20E385	20V385	385	505	300	6500	10000	558	682	1025	100	700
V07E420	7V420	420	560	40	1200	1750	612	748	1120	10	55
V10E420	10V420	420	560	80	2500	3500	612	748	1120	25	140
V14E420	14V420	420	560	160	4500	6000	612	748	1120	50	300
V20E420	20V420	420	560	320	6500	10000	612	748	1120	100	600
V07E440	7V440	440	585	44	1200	1750	643	787	1180	10	50
V10E440	10V440	440	585	85	2500	3500	643	787	1180	25	130
V14E440	14V440	440	585	170	4500	6000	643	787	1180	50	260
V20E440	20V440	440	585	340	6500	10000	643	787	1180	100	500
V07E460	7V460	460	615	48	1200	1750	675	825	1240	10	45
V10E460	10V460	460	615	90	2500	3500	675	825	1240	25	120
V14E460	14V460	460	615	180	4500	6000	675	825	1240	50	220
V20E460	20V460	460	615	360	6500	10000	675	825	1240	100	400
V10E510	10V510	510	670	80	2500	3500	738	902	1355	25	110
V14E510	14V510	510	670	165	4500	6000	738	902	1355	50	200
V20E510	20V510	510	670	325	6500	10000	738	902	1355	100	350

## UltraMOV Series

### Device Ratings and Specifications (Continued)

MODEL NUMBER	DEVICE MODEL NUMBER BRANDING	MAXIMUM RATING (85°C)					CHARACTERISTICS (25°C)				
		CONTINUOUS		TRANSIENT			VARISTOR VOLTAGE AT 1mA DC TEST CURRENT		MAXIMUM CLAMPING VOLTAGE 8 x 20µs		TYPICAL CAPACITANCE
		RMS VOLTS	DC VOLTS	ENERGY 2ms	PEAK CURRENT 8 x 20µs		V <sub>NOM</sub> MIN	V <sub>NOM</sub> MAX	V <sub>C</sub>	I <sub>PK</sub>	f = 1MHz
		V <sub>M(AC)</sub>	V <sub>M(DC)</sub>	W <sub>TM</sub>	I <sub>TM</sub> 2 x PULSE	I <sub>TM</sub> 1 x PULSE					
(V)	(V)	(J)	(A)	(A)	(V)		(V)	(A)	(pF)		
V10E550	10V550	550	745	90	2500	3500	901	1001	1500	25	100
V14E550	14V550	550	745	180	4500	6000	901	1001	1500	50	180
V20E550	20V550	550	745	360	6500	10000	901	1001	1500	100	300
V10E625	10V625	625	825	100	2500	3500	900	1100	1650	25	90
V14E625	14V625	625	825	200	4500	6000	900	1100	1650	50	160
V20E625	20V625	625	825	400	6500	10000	900	1100	1650	100	250

**NOTE:**

1. Average power dissipation of transients should not exceed 0.25W, 0.4W, 0.6W and 1.0W for 7mm, 10mm, 14mm, and 20mm model sizes, respectively.

### Power Dissipation Ratings

Continuous power dissipation capability is not an applicable parameter for a transient suppressor. When transients occur in rapid succession, the average power dissipation is the energy (watt-seconds) per pulse times the number of pulses per second. The power so developed must be within the specifications shown on the Device Ratings and Specifications table for the specific device. Furthermore, the operating values need to be derated at high temperatures as shown in Figure 1. Because varistors can only dissipate a relatively small amount of average power they are, therefore, not suitable for repetitive applications that involve substantial amounts of average power dissipation.

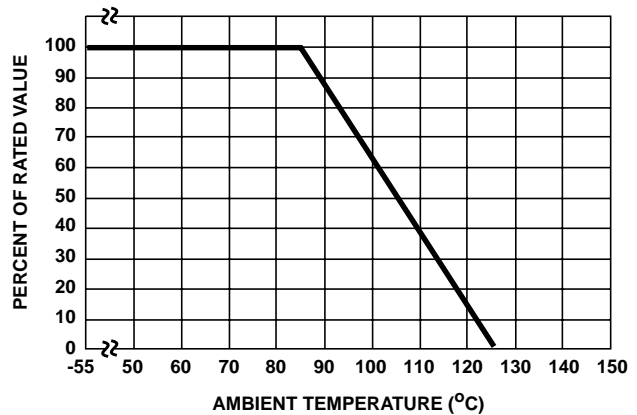

**FIGURE 1. CURRENT, ENERGY AND POWER DERATING CURVE**

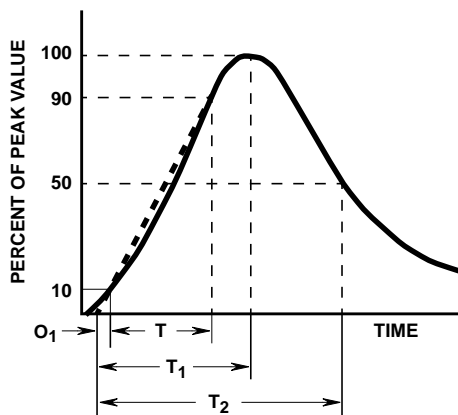

**FIGURE 2. PEAK PULSE CURRENT TEST WAVEFORM**

O<sub>1</sub> = Virtual Origin of Wave  
 T = Time From 10% to 90% of Peak  
 T<sub>1</sub> = Virtual Front time = 1.25 • t  
 T<sub>2</sub> = Virtual Time to Half Value (Impulse Duration)  
 Example: For an 8/20µs Current Waveform:  
 8µs = T<sub>1</sub> = Virtual Front Time  
 20µs = T<sub>2</sub> = Virtual Time to Half Value

Transient V-I Characteristic Curves

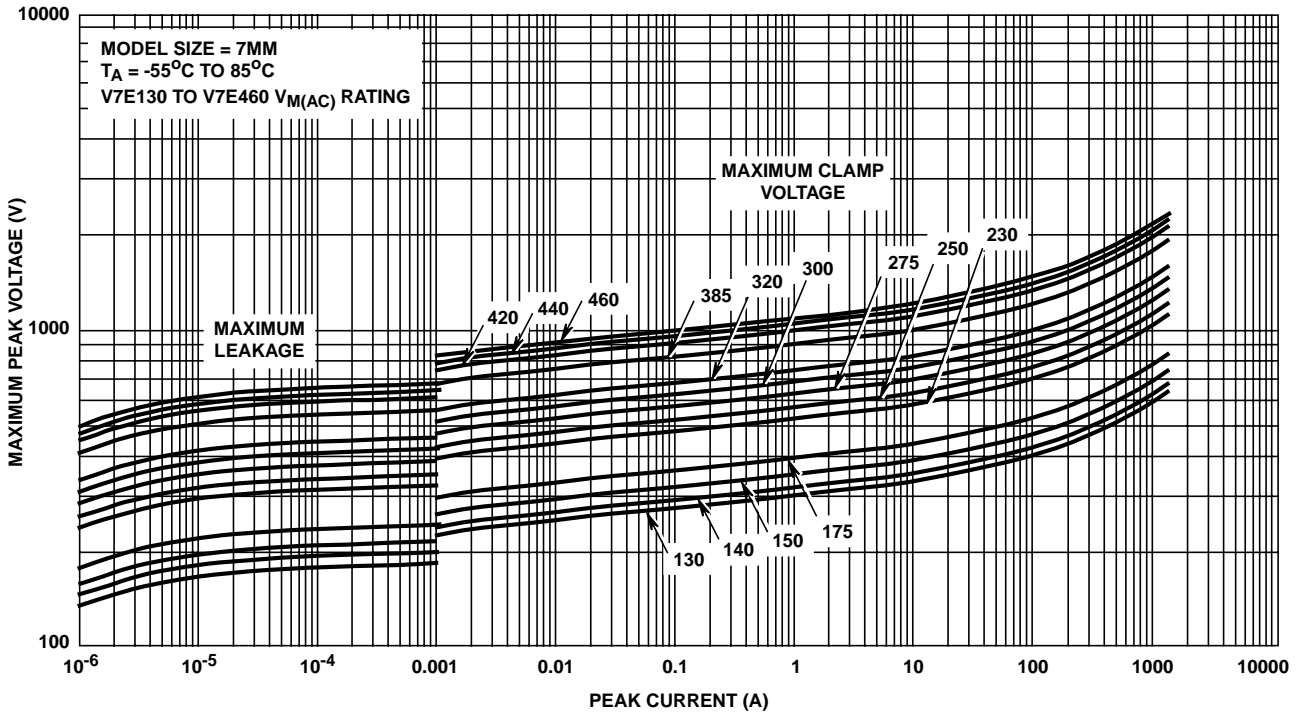

FIGURE 3.

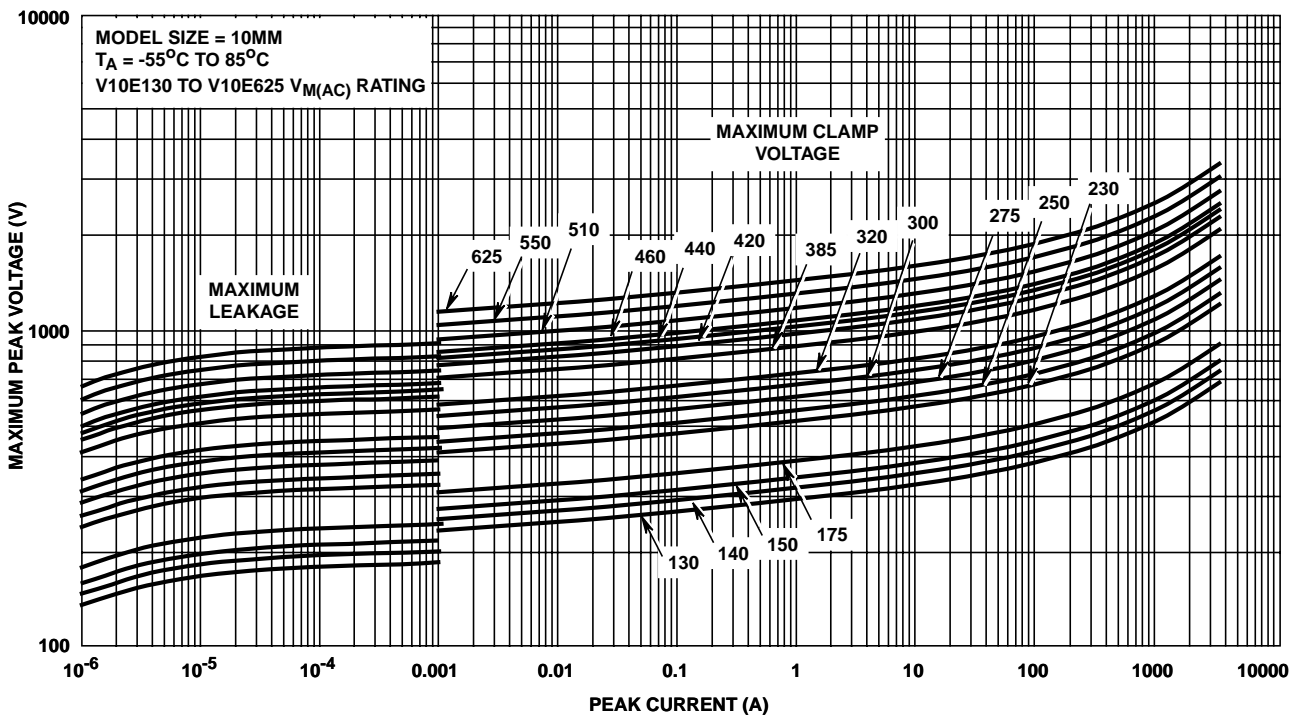

FIGURE 4.

# UltraMOV Series

## Transient V-I Characteristic Curves (Continued)

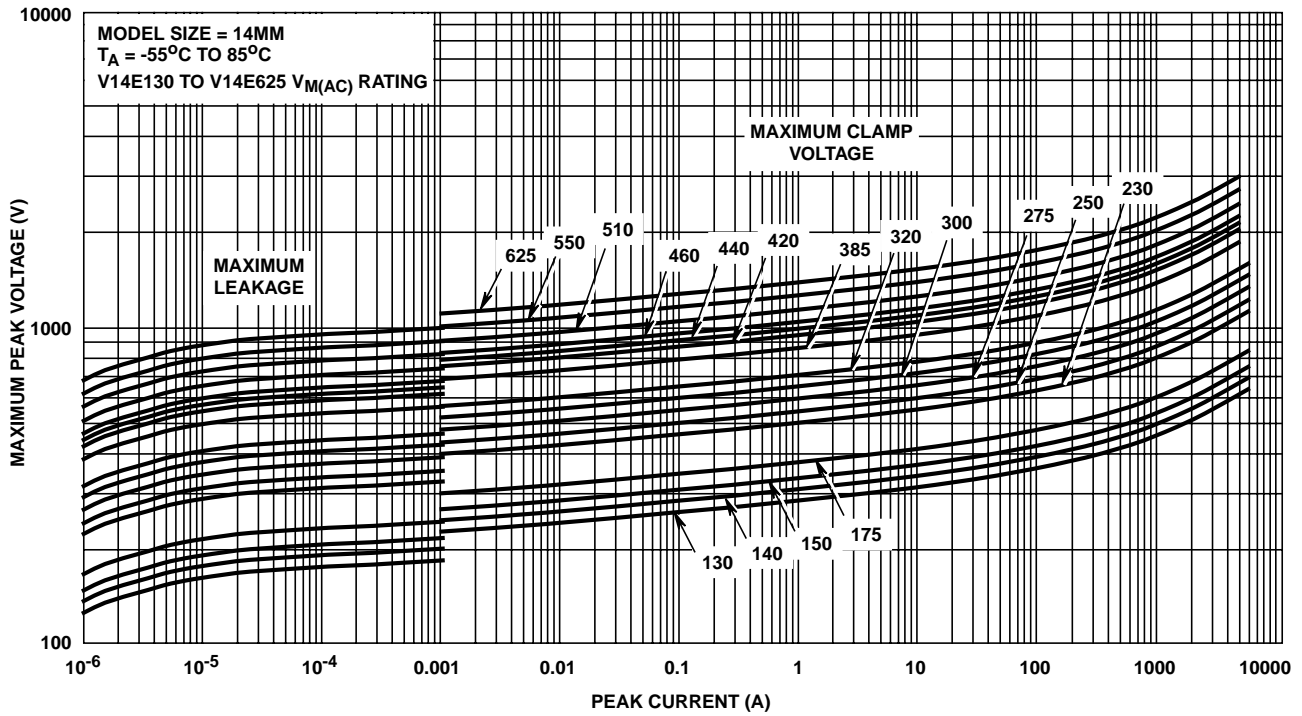

FIGURE 5.

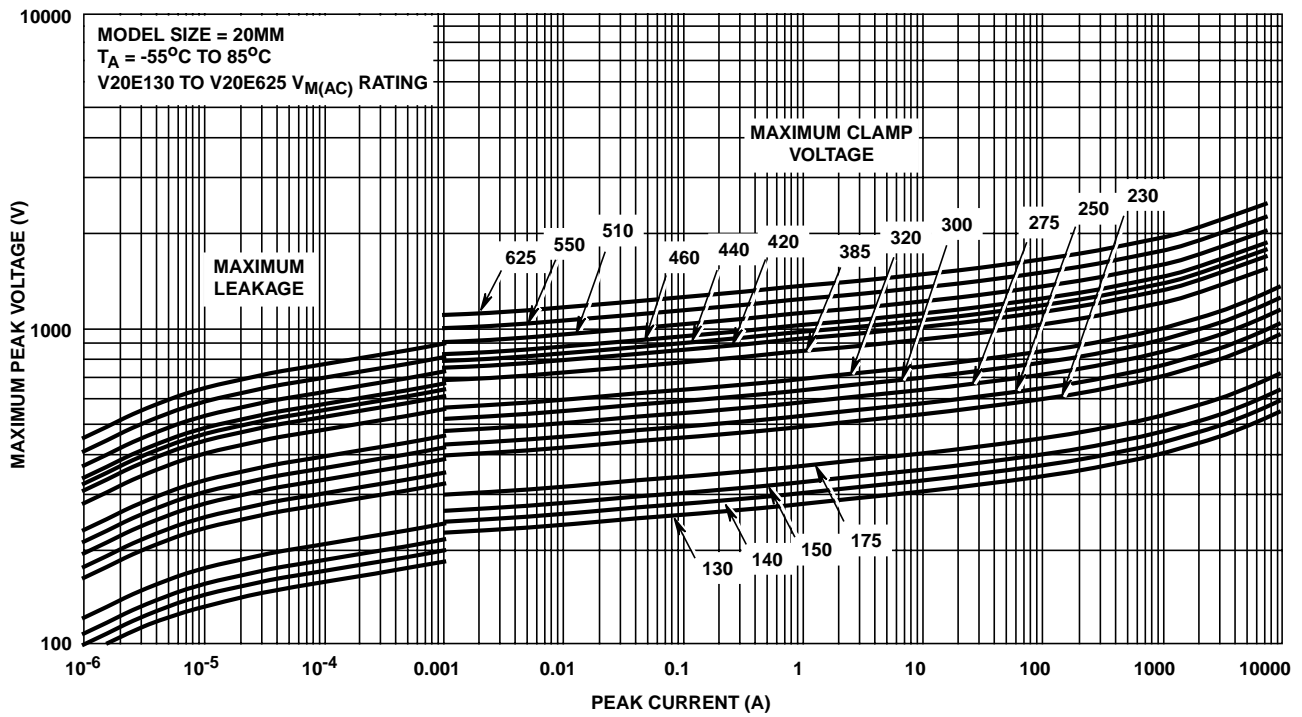

FIGURE 6.

# UltraMOV Series

## Pulse Rating Curves

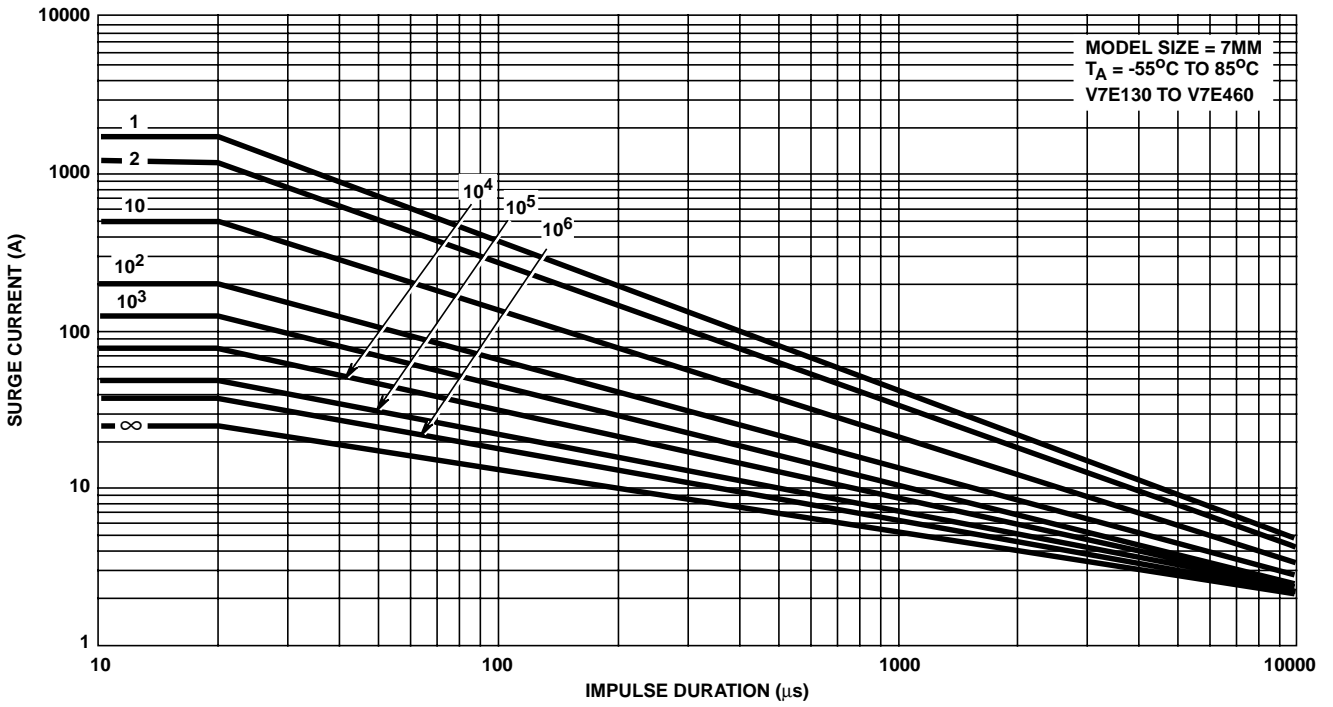

FIGURE 7.

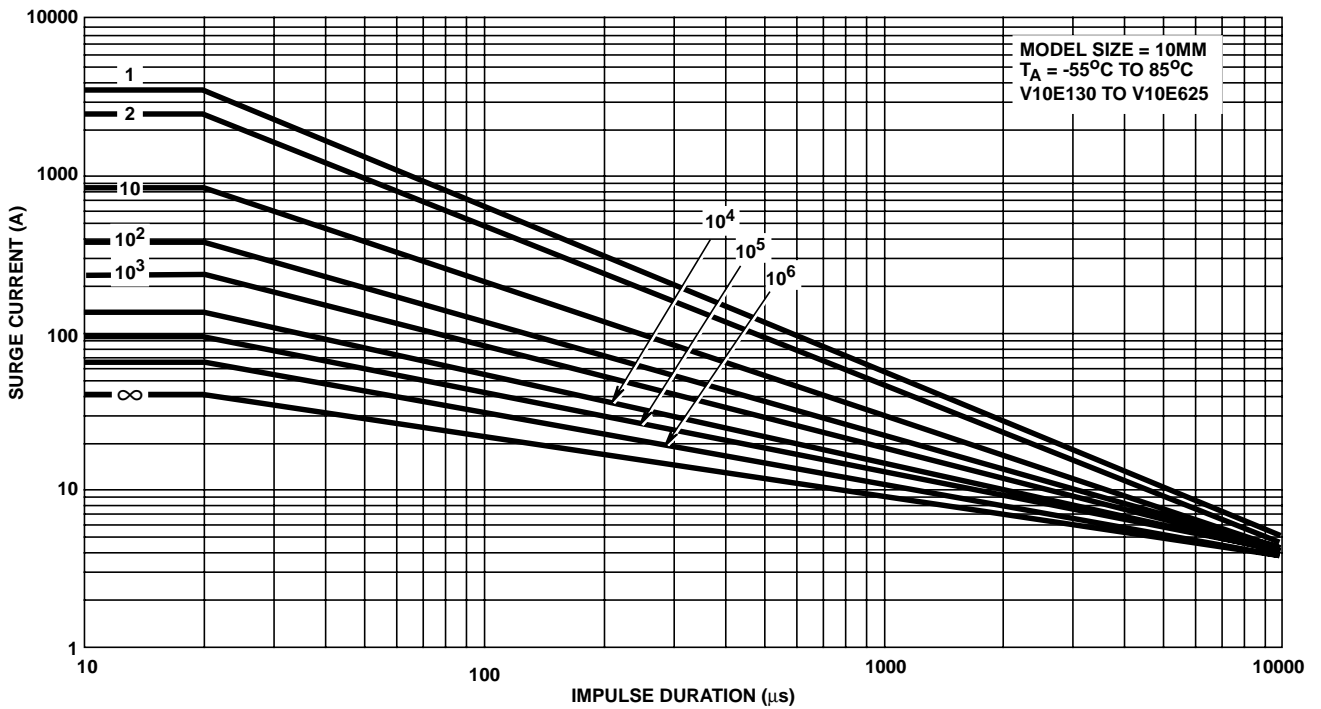

FIGURE 8.

# UltraMOV Series

## Pulse Rating Curves (Continued)

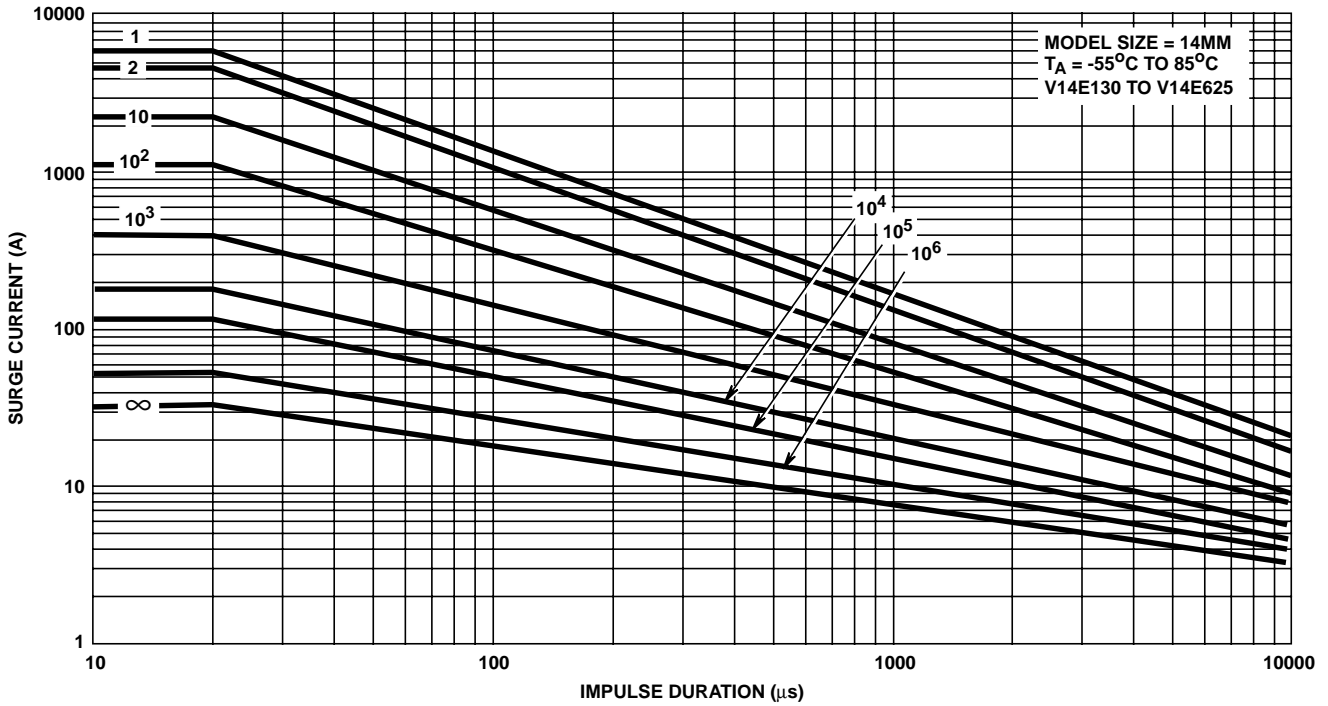

FIGURE 9.

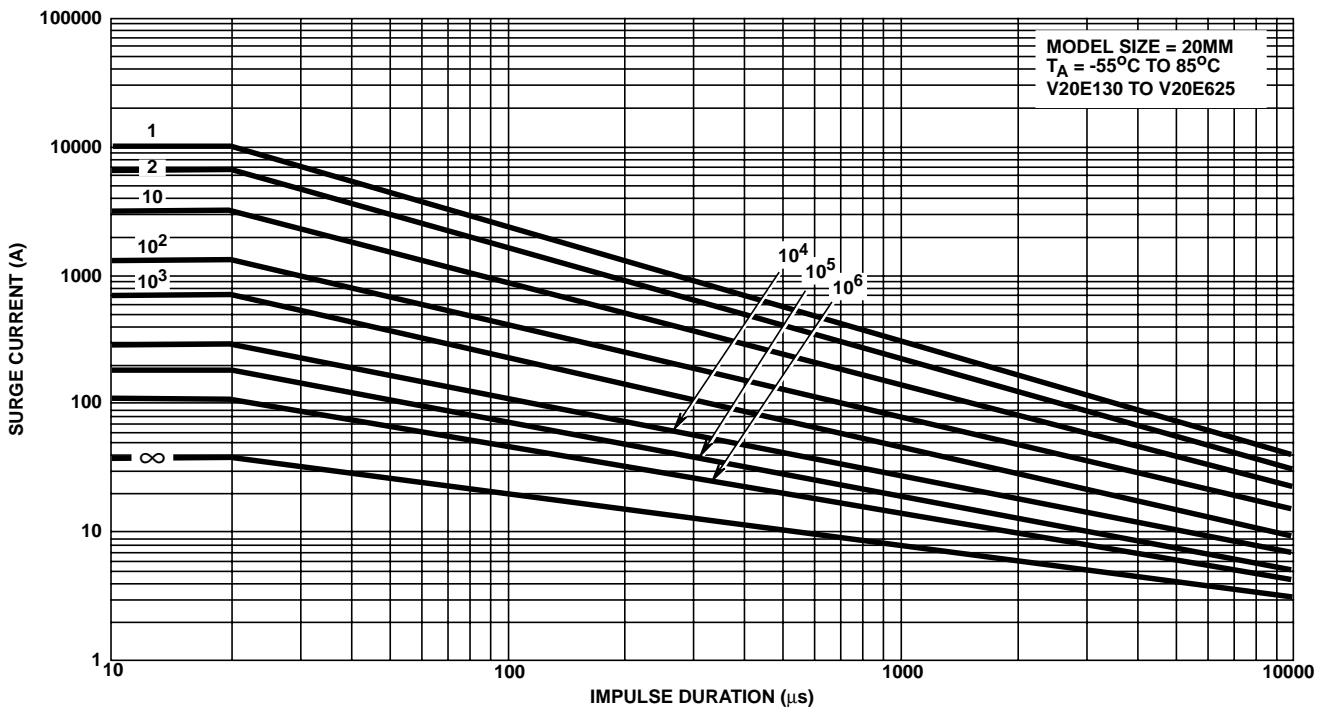
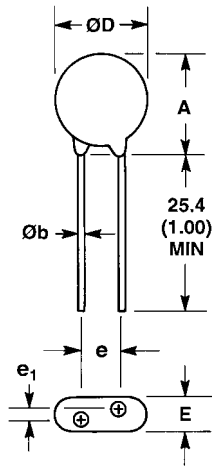

FIGURE 10.



## UltraMOV Series

### Package Outline Dimensions



SYMBOL	V <sub>RMS</sub> VOLTAGE MODEL	VARISTOR MODEL SIZE							
		7mm		10mm		14mm		20mm	
		MIN	MAX	MIN	MAX	MIN	MAX	MIN	MAX
A	130-320	-	12 (0.472)	-	16 (0.630)	-	20 (0.787)	-	26.5 (1.043)
	385-625	-	13 (0.512)	-	17 (0.689)	-	20.5 (0.807)	-	28 (1.102)
ØD	All	-	9 (0.354)	-	12.5 (0.492)	-	17 (0.669)	-	23 (0.906)
e (Note 2)	All	4 (0.157)	6 (0.236)	6.5 (0.256)	8.5 (0.335)	6.5 (0.256)	8.5 (0.335)	9 (0.354) (Note 2)	11 (0.433) (Note 2)
e <sub>1</sub> (Note 3)	130-320	1.5 (0.059)	3.5 (0.138)	1.5 (0.059)	3.5 (0.138)	1.5 (0.059)	3.5 (0.138)	1.5 (0.059)	3.5 (0.138)
	385-625	2.5 (0.098)	5.5 (0.217)	2.5 (0.098)	5.5 (0.217)	2.5 (0.098)	5.5 (0.217)	2.5 (0.098)	5.5 (0.217)
E	130-320	-	5.6 (0.220)	-	5.6 (0.220)	-	5.6 (0.220)	-	5.6 (0.220)
	385-625	-	7.3 (0.287)	-	7.3 (0.287)	-	7.3 (0.287)	-	7.3 (0.287)
Øb	All	0.585 (0.023)	0.685 (0.027)	0.76 (0.030)	0.86 (0.034)	0.76 (0.030)	0.86 (0.034)	0.76 (0.030) (Note 2)	0.86 (0.034) (Note 2)

Dimensions in millimeters, inches in parentheses.

**NOTES:**

2. Standard lead space.
3. For in-line lead option L3, dimension e<sub>1</sub> is "zero". Straight lead form option L1 shown.

### Crimped and Trimmed Lead Dimensions (Lead Form Option L4)

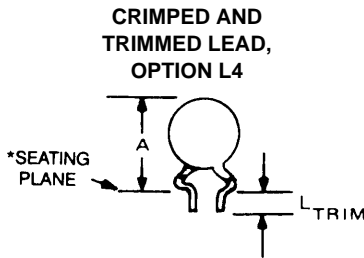

SYMBOL	VARISTOR MODEL SIZE							
	7mm		10mm		14mm		20mm	
	MIN	MAX	MIN	MAX	MIN	MAX	MIN	MAX
A	-	15 (0.591)	-	19.5 (0.768)	-	22.5 (0.886)	-	29.0 (1.142)
L <sub>TRIM</sub>	2.41 (0.095)	4.69 (0.185)	2.41 (0.095)	4.69 (0.185)	2.41 (0.095)	4.69 (0.185)	2.41 (0.095)	4.69 (0.185)

Dimensions in millimeters, inches in parentheses.

\*Seating plane interpretation per IEC-717

(Not available on tape or ammo pack)

### Standard Bulk Pack Quantities

VARISTOR VOLTAGE MODEL	STANDARD BULK PACK QUANTITY			
	VARISTOR MODEL SIZE			
	7mm	10mm	14mm	20mm
130-275	1500	1000	700	500
300-460	1500	700	600	400
510-625	1500	700	500	400

## UltraMOV Series

### Tape Specifications for Reel or Ammo Pack (Fan-Fold)

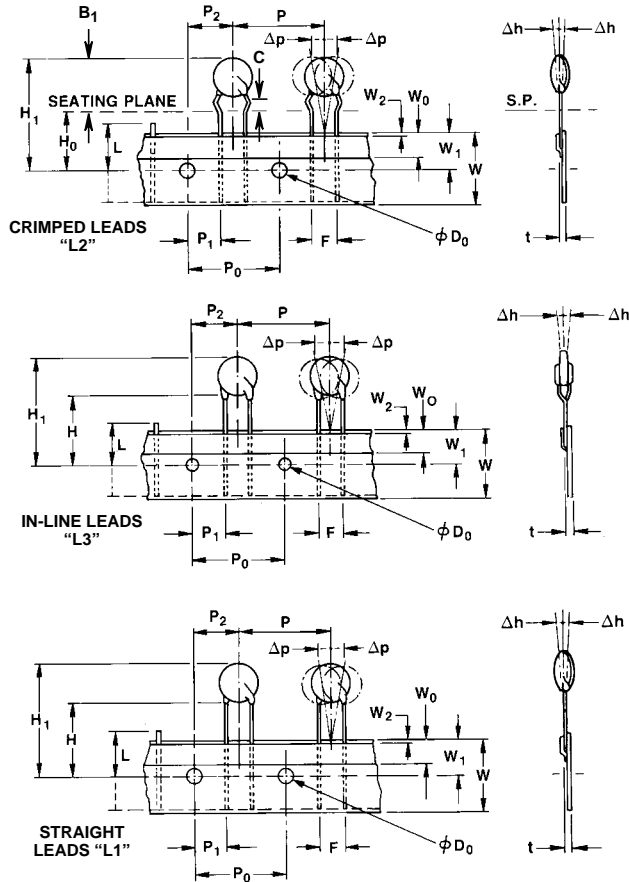

- Conforms to ANSI and EIA specifications.
- Can be supplied to IEC Publication 286-2.
- Radial devices on tape are offered with crimped leads, straight leads, or in-line leads. See Ordering Information.

#### REEL CAPACITY 330mm (13in.)

DEVICE SIZE	SHIPPING QUANTITY PER REEL
7	1000
10	1000
14	500
20	500

SYMBOL	PARAMETER	MODEL SIZE			
		7mm	10mm	14mm	20mm
B <sub>1</sub>	Component Top to Seating Plane	13.75 ±0.75	18.50 ±0.50	21.50 ±0.50	28.00 ±0.50
C	Crimp Length	2.4 Typ	2.6 Typ	2.6 Typ	2.6 Typ
P	Pitch of Component	12.7 ± 1.0	25.4 ± 1.0	25.4 ± 1.0	25.4 ± 1.0
P <sub>0</sub>	Feed Hole Pitch	12.7 ± 0.2	12.7 ± 0.2	12.7 ± 0.2	12.7 ± 0.2
P <sub>1</sub>	Feed Hole Center to Pitch	3.85 ± 0.7	2.6 ± 0.7	2.6 ± 0.7	2.6 ± 0.7
P <sub>2</sub>	Hole Center to Component Center	6.35 ± 0.7	6.35 ± 0.7	6.35 ± 0.7	6.35 ± 0.7
F	Lead to Lead Distance	5.0 ± 0.8	7.5 ± 0.8	7.5 ± 0.8	7.5 ± 0.8
Δh	Component Alignment	2.0 Max	2.0 Max	2.0 Max	2.0 Max
W	Tape Width	18.0 + 1.0 18.0 - 0.5	18.0 + 1.0 18.0 - 0.5	18.0 + 1.0 18.0 - 0.5	18.0 + 1.0 18.0 - 0.5
W <sub>0</sub>	Hold Down Tape Width	6.0 ± 0.3	6.0 ± 0.3	6.0 ± 0.3	12.0 ± 0.3
W <sub>1</sub>	Hole Position	9.0 + 0.75 9.0 - 0.50	9.0 + 0.75 9.0 - 0.50	9.0 + 0.75 9.0 - 0.50	9.0 + 0.75 9.0 - 0.50
W <sub>2</sub>	Hold Down Tape Position	0.5 Max	0.5 Max	0.5 Max	0.5 Max
H	Height from Tape Center to Component Base	18.0 + 2.0 18.0 - 0.0	18.0 + 2.0 18.0 - 0.0	18.0 + 2.0 18.0 - 0.0	18.0 + 2.0 18.0 - 0.0
H <sub>0</sub>	Seating Plane Height	16.0 ± 0.5	16.0 ± 0.5	16.0 ± 0.5	16.0 ± 0.5
H <sub>1</sub>	Component Height	32.0 Max	36.0 Max	40.0 Max	46.5 Max
D <sub>0</sub>	Feed Hole Diameter	4.0 ± 0.2	4.0 ± 0.2	4.0 ± 0.2	4.0 ± 0.2
t	Total Tape Thickness	0.7 ± 0.2	0.7 ± 0.2	0.7 ± 0.2	0.7 ± 0.2
L	Length of Clipped Lead	11.0 Max	11.0 Max	11.0 Max	11.0 Max
Δp	Component Alignment	3° Max, 1.00mm	3° Max, 1.00mm	3° Max, 1.00mm	3° Max

Dimensions are in mm.

## UltraMOV Series

### Model Number Nomenclature

The UltraMOV Series follows a different part numbering procedure than other Harris Varistor products. The base part number consists of the following:

- V = Harris Varistor Designation
- xx = Nominal Disc Diameter (07, 10, 14, 20mm)
- E = Epoxy Encapsulation (Rated to 85°C)
- xxx =  $V_{M(AC)RMS}$  RMS Voltage Rating (130V - 625V)

For example, the model number for a 7mm epoxy coated Varistor rated at 440V RMS is V07E440. (Note that this number will be abbreviated to accommodate marking (laser branding) of the Varistor body. (The part number brand is shown in the Device Ratings and Characteristics table.)

### Ordering Information

To order devices in the UltraMOV Series, the base part number must be appended with lead form, packaging and lead space options as shown below.

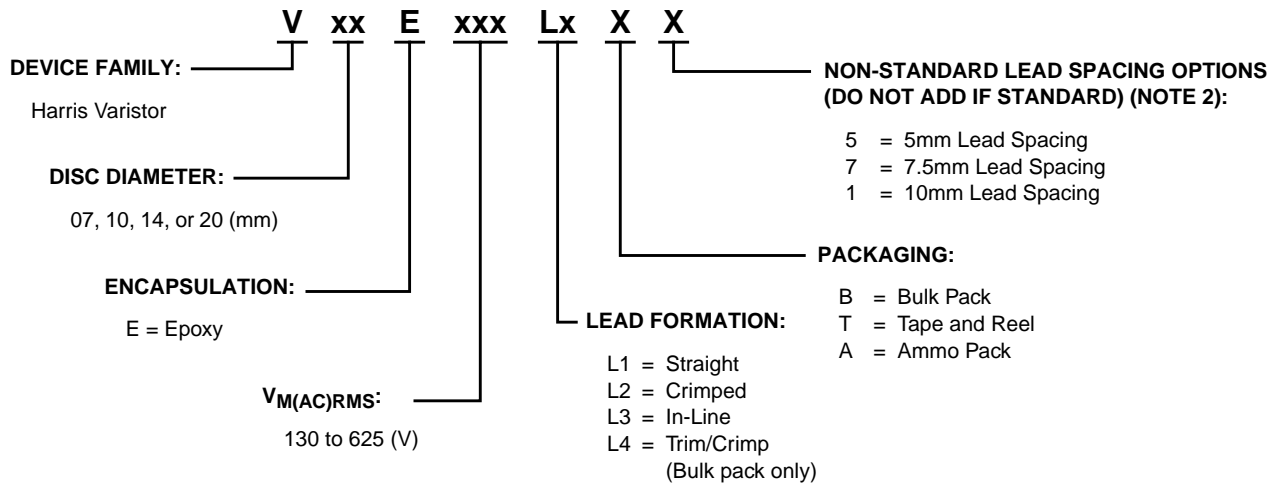

### Terms

#### Rated AC Voltage ( $V_{M(AC)RMS}$ )

This is the maximum continuous sinusoidal voltage which may be applied to the MOV. This voltage may be applied at any temperature up to the maximum operating temperature of 85°C.

#### Maximum Non-Repetitive Surge Current ( $I_{TM}$ )

This is the maximum peak current which may be applied for an 8/20 $\mu$ s impulse, with rated line voltage also applied, without causing device failure. (See Figure 2)

#### Maximum Non-Repetitive Surge Energy ( $W_{TM}$ )

This is the maximum rated transient energy which may be dissipated for a single current pulse at a specified impulse and duration (2ms), with the rated  $V_{RMS}$  applied, without causing device failure.

#### Nominal Voltage ( $V_{N(DC)}$ )

This is the voltage at which the device changes from the off state to the on state and enters its conduction mode of operation. This voltage is characterized at the 1mA point and has specified minimum and maximum voltage levels.

#### Clamping Voltage ( $V_C$ )

This is the peak voltage appearing across the MOV when measured at conditions of specified pulse current amplitude and specified waveform (8/20 $\mu$ s).